

20000005830

IKA®

LR 1000 basic/control_122016

IKA® LR 1000 basic IKA® LR 1000 control

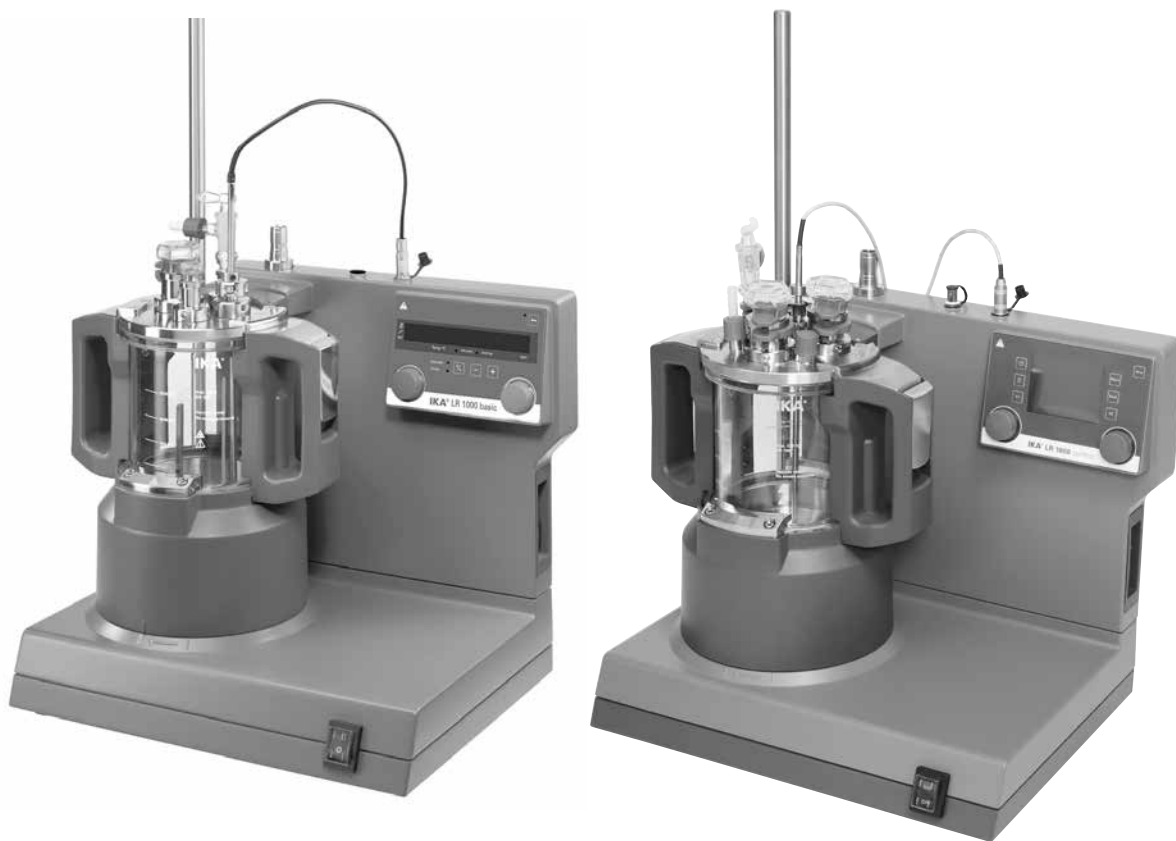

Operating instructions

EN



IKA®-Werke, Germany
Reg. No. 004343

Contents

	Page
Declaration of Conformity	2
Explication of warning symbols	2
Safety instructions	3
Correct use	4
Unpacking	5
System configuration	5
Setting up	7
Safety temperature limit	8
Operator panel and display	9
Commissioning	11
Interface and output	17
Maintenance and cleaning	20
Error codes	22
Warranty	23
Accessories	23
Materials in contact with medium	23
Technical data	24

Declaration of Conformity

We declare under our sole responsibility that this product corresponds to the regulations 2011/65/EU, 2014/30/EU and 2014/35/EU and conforms with the standards or standardized documents: EN 61010-1, EN 61010-2-010, EN 61010-2-051, EN 61326-1, EN 60529 (A1+A2) and EN ISO 12100.

Explication of warning symbols



indicates an imminently hazardous situation, which, if not avoided, will result in death, serious injury.



indicates a potentially hazardous situation, which, if not avoided, can result in death, serious injury.



indicates a potentially hazardous situation, which, if not avoided, can result in injury.



indicates practices which, if not avoided, can result in equipment damage.

Safety instructions

General instructions:

- **Read the operating instructions fully before starting up and follow the safety instructions.**
- Keep the operating instructions in a place where they can be accessed by everyone.
- Ensure that only trained staff work with the equipment.
- Follow the safety instructions, guidelines, occupational health and safety and accident prevention regulations.
- Uncontrolled reactions can be triggered by mixing the heated material insufficiently or by the energy generated by selecting a speed that is too high. In case of these and other increased operational hazards, users must take additional appropriate safety precautions. In any case, when using critical or hazardous materials in your processes, **IKA®** recommends to use additional appropriate measures to ensure safety in the experiment. For example, users can implement measures that inhibit fire or explosions or comprehensive monitoring equipment. Furthermore, users must make sure that the unit switch of the **IKA®** product can be accessed immediately, directly and without risk at any time.



DANGER

If installation or positioning cannot ensure this access at all times, an additional EMERGENCY STOP switch that can be easily accessed must be installed in the work area.

- Only process media that will not react dangerously to the extra energy produced through processing. This also applies to any extra energy produced in other ways, e.g. through light irradiation.
- Do not operate the instrument in explosive atmospheres, with hazardous substances or under water.
- Process pathogenic materials only under a suitable fume hood. Please contact **IKA®** application support if you have any question.
- Set up the device in a spacious area on an even, stable, clean, non-slip, dry and fireproof surface.
- Protect the instrument and accessories from bumping and impacting.
- Check the instrument and accessories beforehand for damage each time when you use them. Do not use damaged components.
- Safe operation is only guaranteed with the accessories described in the "**Accessories**" section.
- Always switch the device switch in the **OFF** position or disconnect the power before changing and fitting any accessories.
- The instrument can only be disconnected from the mains supply by pulling out the mains plug or the connector plug.

- The socket for the mains cord must be easily accessible.
- Socket must be earthed (protective ground contact).
- The voltage stated on the type plate must correspond to the mains voltage.



WARNING

Beware of hazards due to:

- **flammable materials**
 - **combustible media with a low boiling temperature**
 - **glass vessel breakage**
 - **overflowing of media**
 - **unsafe condition of container.**
- The device will automatically restart in mode **B** and **C** following any interruption to the power supply.
 - The equipment is not designed for overpressure use.
 - The equipment is designed for operation at vacuum settings up to 25 mbar.
 - Certain applications and materials may be hazardous. You should take precautions to prevent contact with, or inhalation of, toxic liquids, gases, fumes, vapours or powders.
 - Risks may also be posed by biological or microbiological substances.



WARNING

The reactor system must always be ventilated when working under normal pressure in order to prevent any pressure build-up caused by highly volatile gases or unpredictable reaction pressure gradients. Condense volatile gases using a cooler with a standard ground connector (e.g. a reflux condenser) on the reactor cover.

- Observe the maximum permissible temperatures in the reactor vessel.



NOTICE

Before you fill the reactor vessel, ensure that the reagents used do not corrode the seal.

- Ensure that the external temperature sensor is inserted in the media to a depth of at least 20 mm.
- The external temperature sensor must always be inserted in the media when connected.
- Only use **IKA®** approved accessories!
- Use only original **IKA®** spare parts!
- When the reactor vessel or the vessel cover is removed during operation, the stirring and the heating function will be switched off automatically. Restart the stirring and heating function by pressing on knob **(A)** and **(B)** after the reactor vessel or vessel cover is placed and locked again.

Stirring and dispersing:

- Moving and rotating equipment parts also constitute a hazard.



Rotating tools are dangerous! The anchor stirrer and the dispersing element must only be operated when the reactor vessel is fully closed. Do not start up the laboratory reactor when it is open.

- If the dispersing element rotate when they are covered in a product and the reactor is open, this will cause parts or liquids to be projected outwards.
- Gradually increase the speed.
- The equipment may heat up by stirring.

Heating:



Risk of burns! Exercise caution when touching the heating block and the glass vessel. The cover of the vessel could reach high temperature when you boil liquid for long time. Pay attention to the residual heat after switching off.

Only process and heat up any media that has a flash point higher than the adjusted safe temperature limit that has been set. The safe temperature limit must always be set to at least 25 °C lower than the fire point of the media used.

Cooling:

- Ensure that the thermostat used for tempering is fully efficient. A defective thermostat can cause uncontrolled reactions.



Using the adequate hoses for cooling purposes.

Weighing:



Weighing function integrated into the LR 1000 control feet. Unpack and set up cautiously.

Maintenance:

- The feet of the equipment must be clean and undamaged.
- The device must only be opened by trained specialists, even during repair. The device must be unplugged from the power supply before opening. Live parts inside the instrument may still be live for some time after unplugging from the power supply.



Covering or parts that are capable of being removed from the unit without accessory equipment have to be reattached to the unit for safe operation in order to prevent, for example, the ingress of fluids, foreign matter, etc.

Correct use

Use

The IKA® LR 1000 system is a compact reactor system. It has been designed to simulate and optimize chemical reaction processes and can also be used for mixing, dispersion and homogenization in modeling processes.

Operating mode: Tabletop device.

Range of use (indoor use only)

- Laboratories
- Pharmacies
- Schools
- Universities

This equipment is suitable for use in all areas except:

- Residential areas
- Areas that are connected directly to a low-voltage supply network that also supplies residential areas.

The safety of the user cannot be guaranteed:

- if the instrument is operated with accessories that are not supplied or recommended by the manufacturer
- if the instrument is operated improperly or contrary to the manufacturer's specifications
- if the instrument or the printed circuit board are modified by third parties.

Unpacking

Unpacking

- Please unpack the device carefully
- In the case of any damage a detailed report must be sent immediately (post, rail or forwarder).

Delivery scope

LR 1000 basic:

- **LR 1000 basic** base
- Reactor vessel **LR 1000.1** (see Fig. 4)
- Temperature sensor
- Receptacle for temperature sensor
- Support rod
- 2 pieces hose connectors
- Mains cable
- Tool kit (see Fig. 1)
- Operating Instructions
- Warranty card.

LR 1000 control:

- **LR 1000 control** base
- Reactor vessel **LR 1000.3** (see Fig. 5)

- Temperature sensor
- Receptacle for temperature sensor
- Support rod
- 2 pieces hose connectors
- USB cable
- Mains cable
- Tool kit (see Fig. 1)
- Operating Instructions
- Warranty card.



System configuration

IKA® LR 1000 basic/control laboratory reactor comprises:

LR 1000 basic/control base:

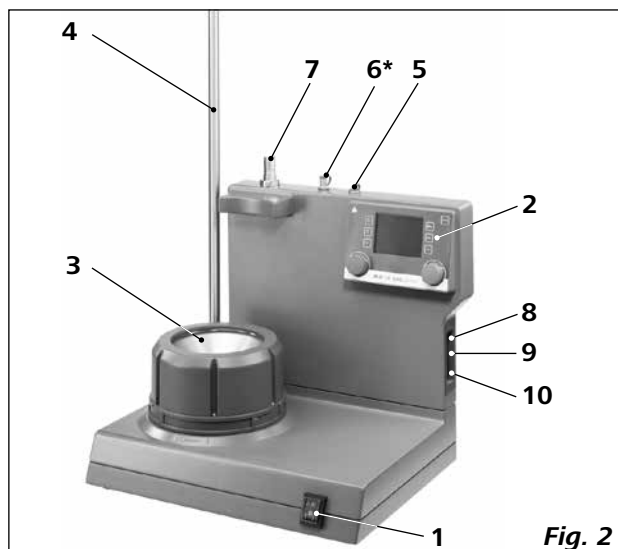

Fig. 2

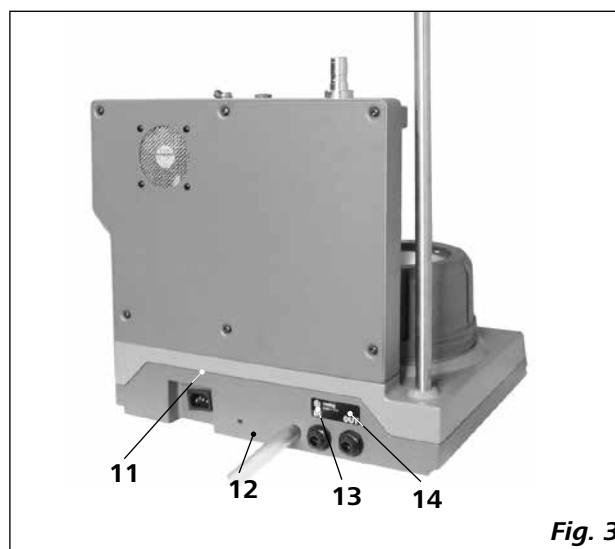

Fig. 3

- 1: Mains switch
- 2: Control elements and display
- 3: Heating block (with integrated cooling coils for connecting external cooling systems)
- 4: Support rod, for securing accessories
- 5: Temperature sensor socket
- 6*: pH-probe socket (for **LR 1000 control** only)
- 7: Reception for disperser (Park station)

- 8: Adjustable safety circuit
- 9: USB port
- 10: RS 232 port
- 11: Power socket
- 12: Condensate drain*
- 13: Cooling connection **IN***
- 14: Cooling connection **OUT***

***Note:** Cooling connections can be used only for cooling purpose.

Reactor vessel (LR 1000.1):

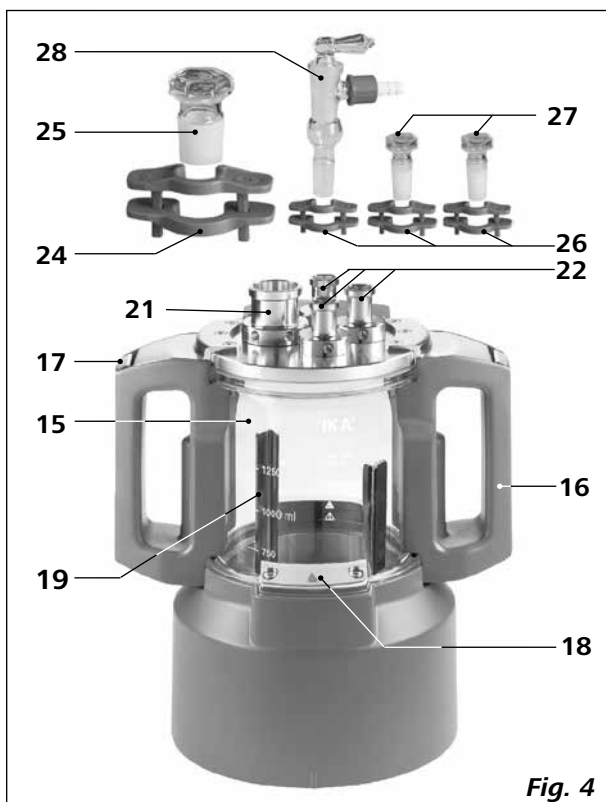

Fig. 4

- 15: Glass vessel (Borosilicate glass 3.3)
- 16: Handle
- 17: Cover latch
- 18: Vessel locker
- 19: Anchor stirrer
- 21: **NS 29/32** (1x)
- 22: **NS 14/23** (3x)
- 24: Safety clips **NS 29/32** (1x)
- 25: Stopper **NS 29/32** (1x)
- 26: Safety clips **NS 14/23** (3x)
- 27: Stopper **NS 14/23** (2x)
- 28: Vacuum cock **NS 14/23** (1x)

Reactor vessel (LR 1000.3):

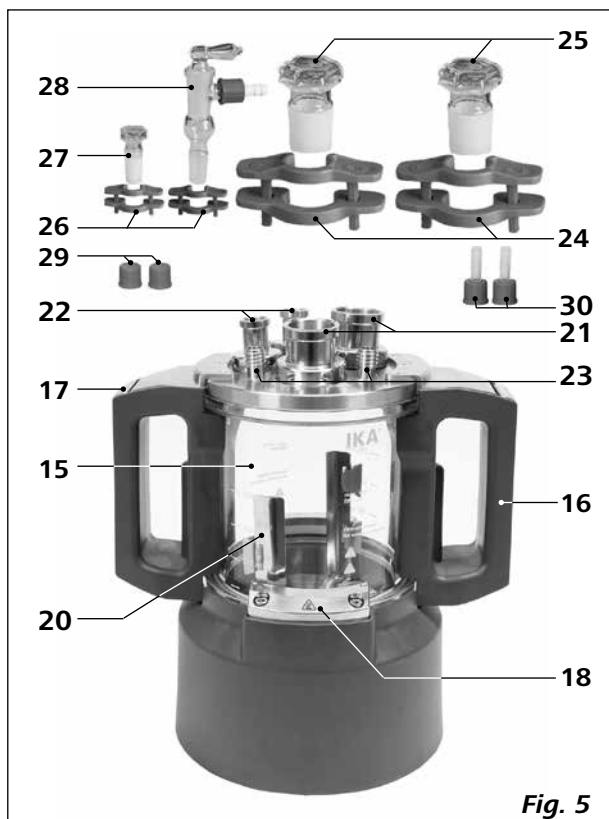

Fig. 5

- 15: Glass vessel (Borosilicate glass 3.3)
- 16: Handle
- 17: Cover latch
- 18: Vessel locker
- 20: Anchor stirrer with scraper (PEEK)
- 21: **NS 29/32** (2x)
- 22: **NS 14/23** (2x)
- 23: Neck with **GL 14** thread (2x)
- 24: Safety clips **NS 29/32** (2x)
- 25: Stopper **NS 29/32** (2x)
- 26: Safety clips **NS 14/23** (2x)
- 27: Stopper **NS 14/23** (1x)
- 28: Vacuum cock **NS 14/23** (1x)
- 29: Screw cap **GL 14** (2x)
- 30: Hose connector and nut **GL 14** (2x)

Setting up

Support rod:

Screw the support rod onto the **LR 1000 basic/control** base with the double open end wrench included with the device until the end stop is reached.

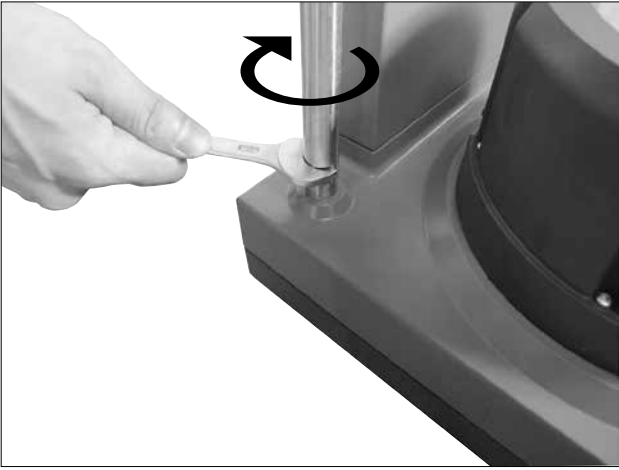

Fig. 6

Attach the reactor vessel to the LR 1000 basic/control base:

Ensure the **LR 1000 basic/control** is set up on an even, stable, clean and non-slip working table.

Set the reactor vessel to the **LR 1000 basic/control** base carefully and ensure it is properly attached as indicated in following image.

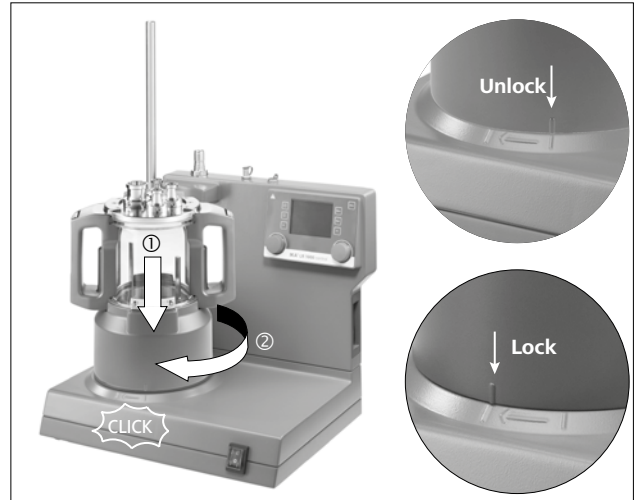

Fig. 7

Installation and connection Pt 100 temperature sensor:

Remove a standard connection **NS 14/23** from the reactor cover for connection the temperature probe.

Screw the **LR 1000.61** sensor receptacle with sealing in the reactor cover.

Plug in the probe and pay attention to the minimum immersion depth and freewheeling of the anchor mixer. Fix the position in the housing with the two screws for sliding stop.

Connect the temperature probe with the appropriate socket.

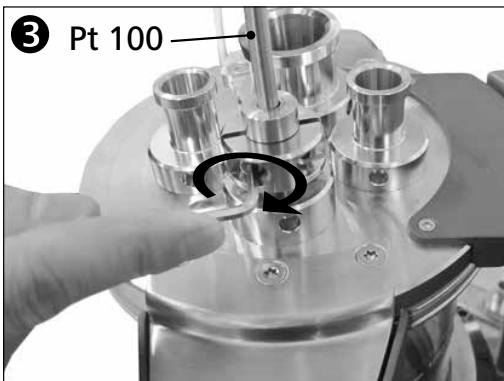

Fig. 8

Connect external cooler:

The reactor can connect an external cooler (e.g. IKA® RC 2 basic or RC 2 control) via the connections (13, 14, see Fig. 3) at the back of the device. The cooling connections **IN** and **OUT** is labelled accordingly at the back of the device. There are two connectors included for connecting cooling hoses. They can be connected to a hose with a 10 mm inner diameter. By positioning and light pressure in the direction of the connector, the connector is locked/connected to the cooling connections **IN/OUT** on the housing. The connectors are unlocked by coaxially positioning the unlocking lever and pressing slightly.



Fig. 9

Safety temperature limit

The maximum attainable heating temperature is restricted by an adjustable safety circuit. Once the safety temperature has been attained, the instrument switches off the heating function.



WARNING

The safety temperature must always be set to at least 25 °C lower than the flash point of the fluid used.

Factory setting: max. value

Setting the safety temperature limit

After switching on the instrument, the safety temperature can be adjusted with screwdriver delivered with the device. The safety temperature setting will appear on the display.



NOTICE

Do not turn the potentiometer beyond the clockwise or anti-clockwise stop, since this will damage the potentiometer irreparably.

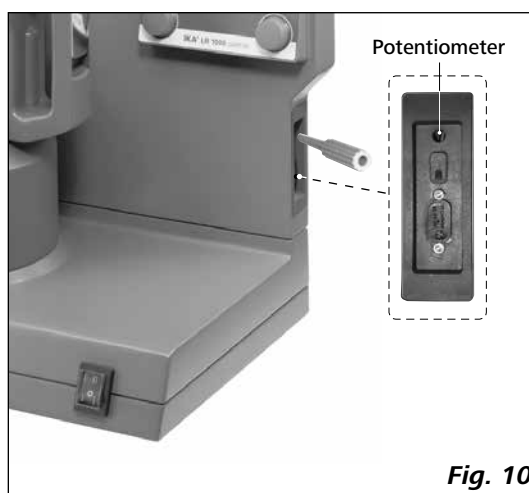

Fig. 10

Operator panel and display

LR 1000 basic:

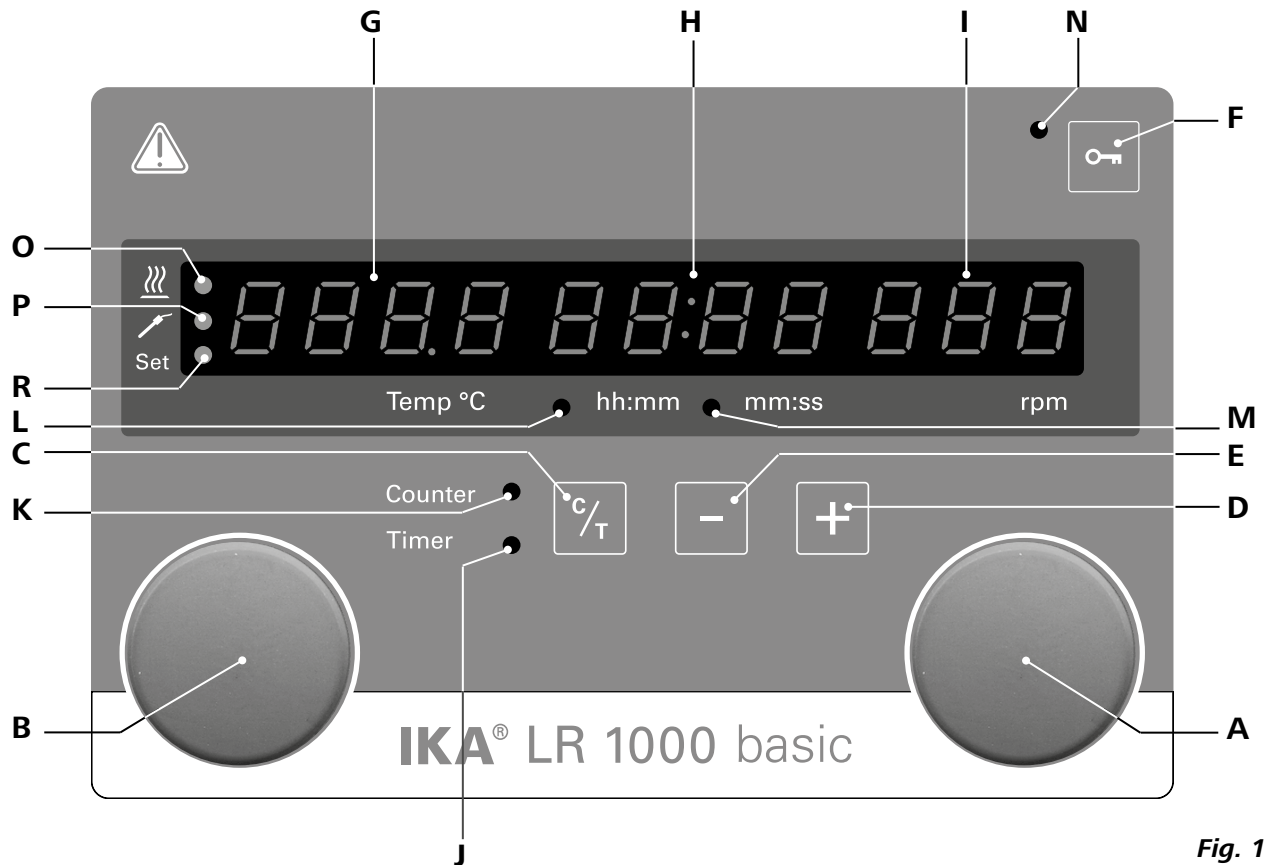

Fig. 11

Item Designation	Function
A Rotating/pressing knob:	Start/stop the stirring function Change the settings of stirring speed
B Rotating/pressing knob:	Start/stop the heating function Change the settings of the temperature
C Counter/Timer (C/T) button:	Switch between "Counter" and "Timer" function
D Timer (+):	Increase the "Timer" value
E Timer (-):	Decrease the "Timer" value
F Lock key:	Lock/unlock knobs and keys
G Display, temperature:	Display the set and actual temperature
H Display, counter/timer:	Display the counter and timer values
I Display, stirring speed	Display the set and actual stirrer speed
J LED, timer	The LED indicates the "Timer" function is activated
K LED, counter	The LED indicates the "Counter" function is activated
L LED, hh:mm	The LED indicates the "Timer" or "Counter" is working with unit hh:mm
M LED, mm:ss	The LED indicates the "Timer" or "Counter" is working with unit mm:ss
N LED, key button	Indicates that the function of key and knobs is deactivated
O LED, heating	The LED indicates the heating function is activated
P LED, temperature sensor	The LED indicates the external temperature sensor is connected
R LED, Set	The LED lights simultaneously with the display of the set value for heating function.

LR 1000 control:

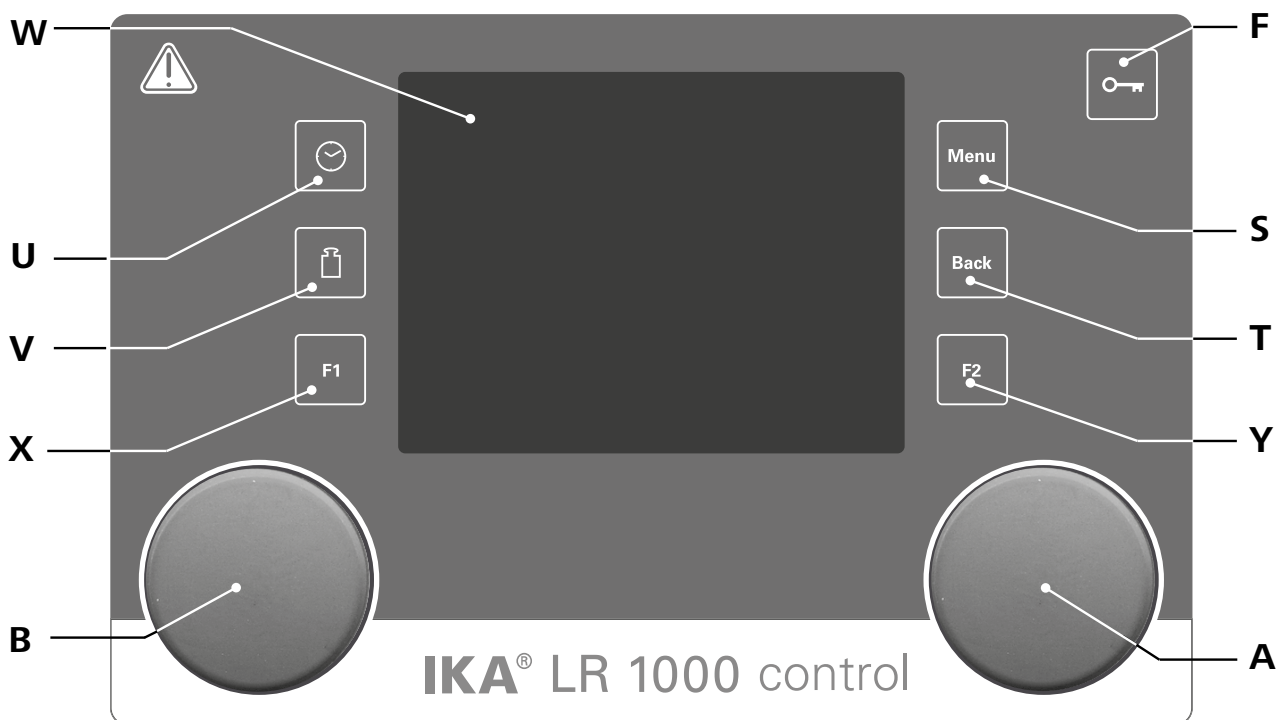
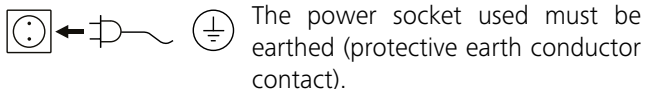

Fig. 12

Item	Designation	Function
A	Rotating/pressing knob:	Start/stop the stirring function Change the settings of stirring speed in working screen Navigation, selecting and changing the settings in the menu
B	Rotating/pressing knob:	Start/stop the heating function Change the settings of the temperature in working screen
F	Lock key:	Lock/unlock knobs and keys
S	"Menu" button:	Press it once: main menu is displayed Press it a second time: back to the working screen
T	"Back" button:	Return to the previous menu level
U	Timer button:	Enable timer display
V	Weighing button:	Enable weight display
W	Display:	Display and setting information
X	F1 button:	not currently assigned
Y	F2 button:	not currently assigned

Commissioning

Check whether the voltage specified on the type plate (**LR 1000 basic/control** base) matches the mains voltage available.



If these conditions are met, the device is ready for operating after plugging in the mains plug.

If these procedures are not followed, safe operation cannot be guaranteed and/or the equipment may be damaged.

Observe the ambient conditions (temperature, humidity, etc.) listed under "**Technical Data**".

• LR 1000 basic

Switch on the instrument:

After switching on the mains switch on the front of the device, all LED segments light up during the self-test. Then the software version, operation mode, safety temperature and working settings will be shown. Then the device enters standby status and is ready for operation.



Fig. 13

Turn the rotating/pressing knob (**A**), the speed value can be adjusted. Press right rotating/pressing knob (**A**, see **Fig. 11**) to activate the stirring function.

Turn the rotating/pressing knob (**B**), the temperature value can be adjusted. Press left rotating/pressing knob (**B**, see **Fig. 11**) to activate the heating function.

Operation mode

The instrument can be operated in three different modes (A, B, C).

Operation mode A:

After power on/power failure no automatic restart of functions.

Operation mode B:

After power on/power failure automatic restart of functions, depending on previous settings.

Operation mode C:

Set values (set in **A** or **B**) cannot be changed. After power on/power failure automatic restart of functions, depending on previous settings.

Factory setting: mode A

Changing the mode

☞ Switch off the instrument with the mains switch

☞ Press and hold rotating/pressing knob (**B**)

☞ Switch on the instrument with the mains switch

☞ Release rotating/pressing knob (**B**)

⇒ The operation mode will be change to next operation mode in the sequence **A – B – C – A – B – C – A** etc.

Heating function:

The heating function can be started or stopped by pressing the left rotating/pressing knob (**B**). Then, the target temperature value and the actual temperature value will appear on display (**G**, see **Fig. 11**) alternately. When the set temperature value is display, LED (**R**, see **Fig. 11**) lights up. The heating temperature value can be adjusted by turning the left rotating/pressing knob (**B**). The value could be changed in standby or operation process.

Temperature sensor calibration:

☞ Press and hold the Knob **B** for more than 5 seconds to enter calibration mode.

⇒ "CAL" will be shown on display (**H**)

☞ Turn Knob **B** to adjust the value on display (**G**) to the calibration value.

☞ Press Knob **A** to confirm the value and finish the calibration.

Note: Pressing and holding the knob **A** for more than 5 second will reset the calibration to factory setting.

Counter and timer function:

Counter function:

When the heating function is started, the counter will start automatically. The counter is displayed with 4 digits.

When the operating time is less than 1 hour, the counter work with minute/second (**mm:ss**) mode and LED (**M**, see **Fig. 11**) lights.

If the operating time exceeds 1 hour, the display switches from minute/second mode to hour/minute (**hh:mm**) mode. LED (**L**, see **Fig. 11**) lights indicate the status.

If the operating time exceeds 100 hours, the display switches from hour/minute mode **99:59** to hour mode **h 100**.

In hour mode, only whole hours are displayed.

In day mode, only whole days are displayed.

h 9999 — Hour mode

d 100 — Day mode

Timer function:

The **Time (+)** button (**D**, see **Fig. 11**) or **Time (-)** button (**D**, see **Fig. 11**) is used to adjust the heating time. If the timer value is more than 1 hour, the display switch to hour/minute (**hh:mm**) mode from minute/second (**mm:ss**) mode. The LED (**L**) lights.

The max. value for timer is 99:59 (**hh:mm**).

Switching between "Counter" and "Timer" function:

The "**Counter**" function could be switch to "**Timer**" function by pressing the **Counter/Timer** key (**C**, see **Fig. 11**). The timer LED (**J**, see **Fig. 11**) indicates the "**Timer**" function is activated.

Press the **Counter/Timer** key (**C**) again, the "**Counter**" function will be activated and counter LED (**K**, see **Fig. 11**) lights.

Stirring function:

The stirring function can be started or stopped by pressing the right rotating/pressing knob (**A**). The speed can be adjusted during operation.

The displayed value will flash until reaching the target speed.

• LR 1000 control:

Switch on the device:

After switching on the device using the power switch on the front panel the device name and the software version are displayed on the screen.



Fig. 14

After a few seconds, the working screen is shown on the screen, device is ready for operation.

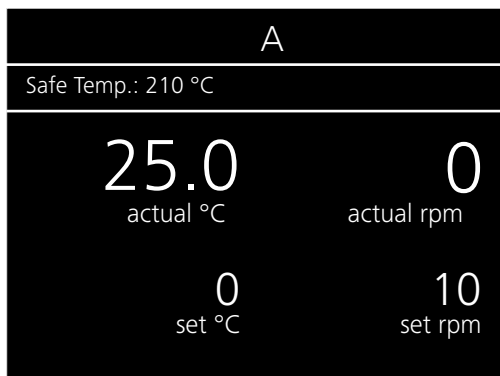

Fig. 15

Turn the rotating/pressing knob (**A**), the target speed setting can be adjusted on the working screen. Press rotating/pressing knob (**A**, see **Fig. 12**), the stirrer start to running. Turn the rotating/pressing knob (**B**), the temperature set-point can be adjusted. Press rotating/pressing knob (**B**, see **Fig. 12**) to activate the heating function.

Explanation of symbols on the working screen:

The symbols displayed change depending on the status and settings of the instrument. The screen below shows the most significant symbols on the working screen.

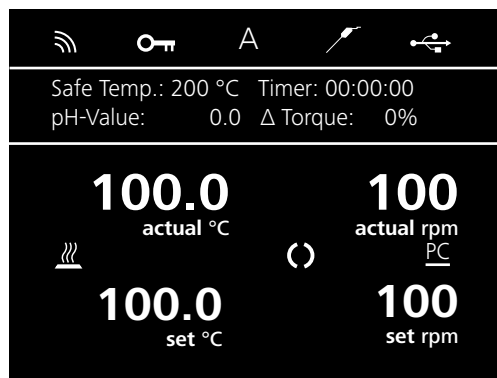

Fig. 16

Lock Key:

This symbol means that the function of the keys and the rotary knobs for controlling the device are disabled. The symbol no longer appears if the functions are enabled once again by pressing the key button a second time.



Temperature Sensor:

This symbol appears when the external temperature sensor is connected.

A Operating Mode:

This symbol indicates the operating mode currently selected (A, B, C).





USB:

This symbol means the device is communicating via a USB cable.



Heating:

This symbol indicated the heating function is activated.  →  →  indicated active heating process.



Motor activated:

This symbol indicates the rotation status of the stirrer.



PC control:

This symbol indicates the device is control via a PC.

Menu navigation and structure:

Menu navigation:

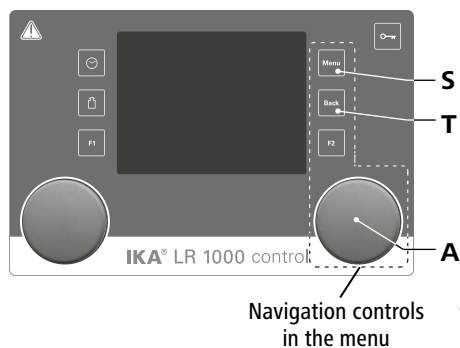

Fig. 17

- Press the "Menu" key (S).
- Select the menu by turning the rotating/pressing knob (A) to the right or left to select the desired menu or sub-menu, which can then be selected by pressing the rotating/pressing knob (A).
- Push or Turn the rotating/pressing knob (A) again to select the desired menu option and edit the values or settings, or activate/deactivate a function.
- Turn the rotating/pressing knob (A) on "OK" or Press the "Back" key (T) or "Menu" button (S) to end the procedure and return to previous menu or working screen.

Note: The display shows the activated menu option highlighted in yellow color.

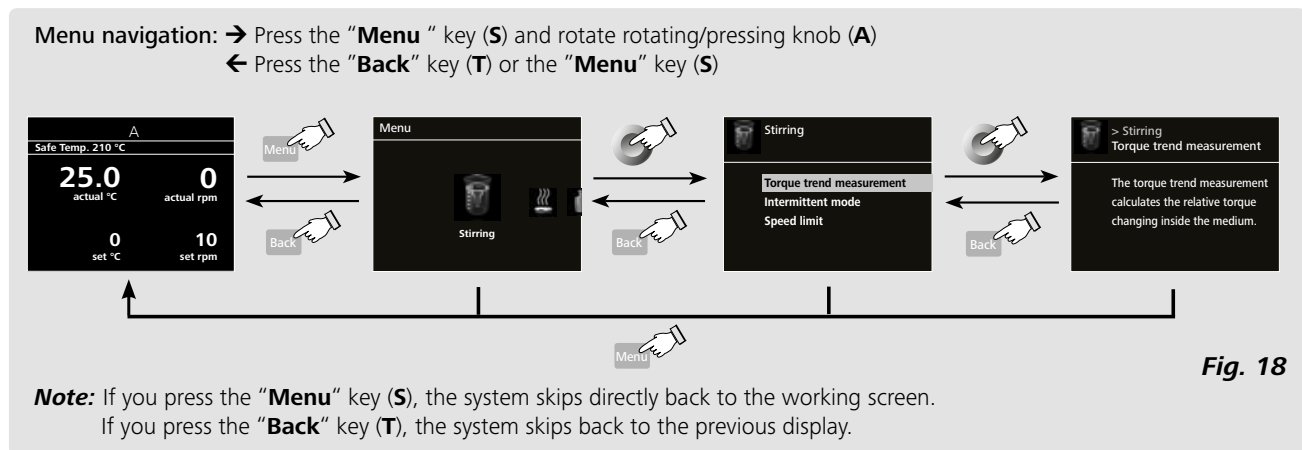
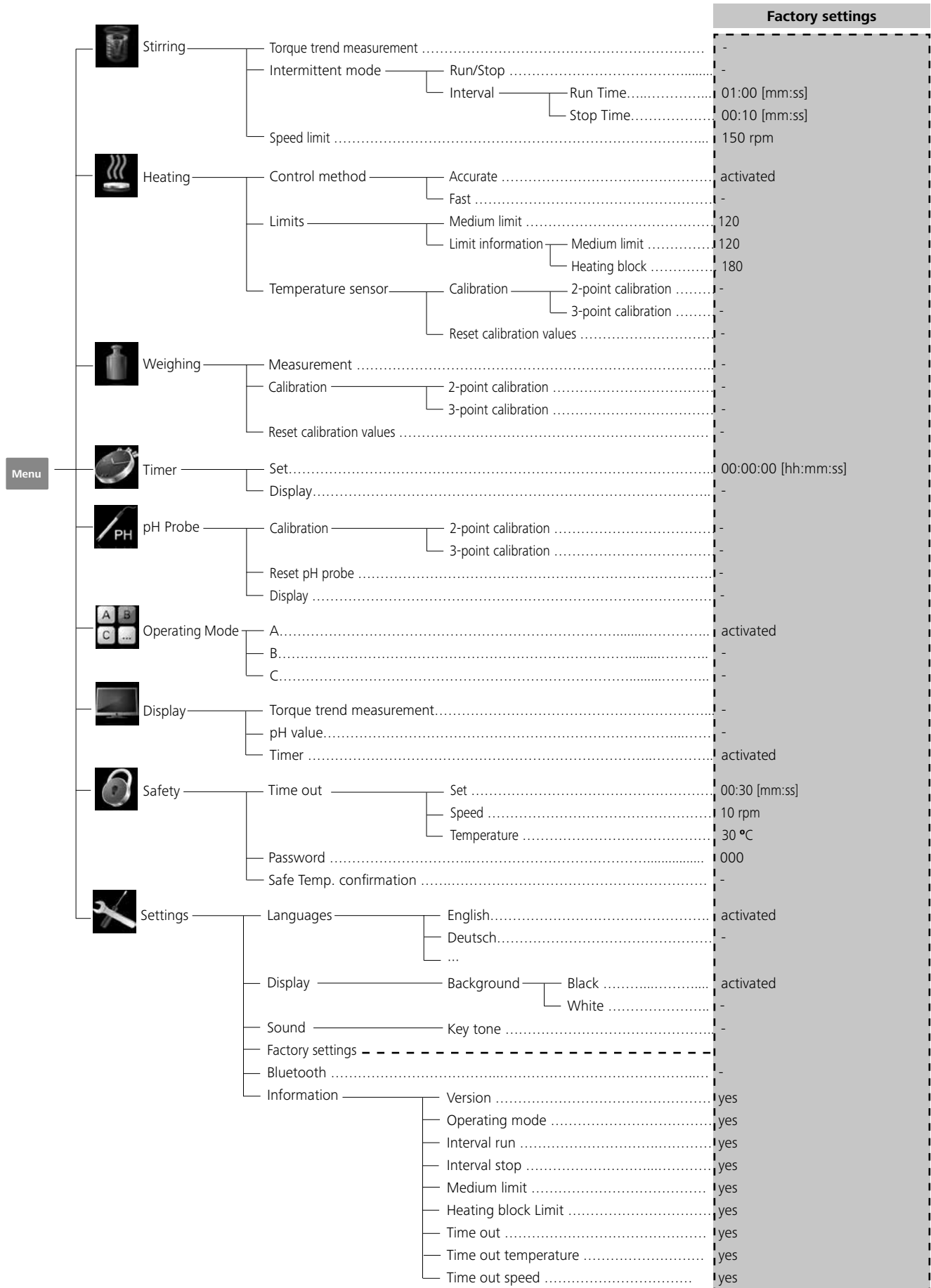

Fig. 18

Menu structure:



Menu (Details):



Stirring:

Torque trend measurement:

The torque trend measurement is used to deduce the change in viscosity of the reaction medium. The device is **not** designed to measure absolute viscosity. It only measure and display the relative change in the viscosity of the medium from a starting point specified by the user.

The value can always be reset to 0% by pressing the “**Back**” (T, see **Fig. 12**) membrane key.

Note: Torque trend measurement only works for a constant set speed for the duration of the measurement.

As a result, intermittent mode cannot be used in conjunction with torque trend measurement.

The current control variable is saved as the reference 0%, ΔP and shown on the digital display. The change in the viscosity is then shown in %. Depending on whether the viscosity increases or decreases, the percentage rises or falls above or below 0% respectively.

Intermittent mode:

The menu allows the user to activate the “**Run/Stop**” function. The run time and stop time can be set separately.

Speed limit:

The menu allows the user to set the desired maximum upper speed limit for the reactor system. The initial setting is the maximum permissible speed of the stirrer. If the user changes this setting, control system of the reactor saves the new value for future stirring tasks.

If the “**Speed Limit**” has been changed, then the speed can be adjusted only within the new range.



Heating:

Control mode:

In the menu, the user is allowed to select “**Accurate**” or “**Fast**” control mode by rotating and pressing knob (A). The selected control mode is indicated by a tick.

Fast: reach target temperature quickly but with big overshoot and large hysteresis at the beginning.

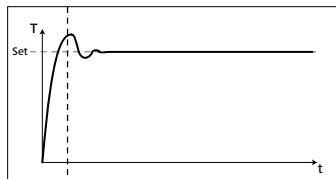

Accurate: Reach the target temperature takes somewhat longer, but for this reason, the initial overshoot and the hysteresis are significantly smaller.

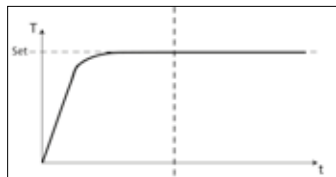

Limits:

In “**External (ext)**” option, the user is allowed to set the maximum and minimum temperature for external temperature control. Confirm and store the setting by pressing on “**OK**”.

Temperature sensor:

In “**Calibration**” option, the user is allowed to calibrate the external temperature sensor.



Weighing:

Measurement:

With the weighing function, the user can perform simple weighing tasks.

Note: The heating and stirring functions must be deactivated.

Calibration:

- Open the “**Calibration**” submenu and confirm by pressing the rotary knob (A, see **Fig. 12**)
- Enter the calibration weight and confirm by pressing the rotary knob (A, see **Fig. 12**).
- Place the calibration weight on the device and wait until the device indicates that the calibration process has been completed.

Depending on the selected calibration mode, 2-point or 3-point must follow these steps two or three times.

Once the calibration process has been completed successfully, the weighing module is ready for use.

Regularly re-calibrate the device.



Timer:

In the menu the user can specify that the timer is displayed on the working screen. A tick shows that the option is activated. This setting allows the user to specify the actual time for the heating procedure.

A default time can also be set for the timer. This setting allows the user to start the heating task for a standard time. The device stops automatically after expiry of the set time, and the set time used for the heating procedure appears in the display.

Note: The user can stop the stirring function before expiry of the set time. In this case the countdown of the timer is interrupted.



pH Probe:

Calibration:

The pH Probe must be calibrated before being used to attempt a pH measurement.

The calibration is used to adjust the pH probe and the device so that they work together correctly. As part of the process, the neutral and pH gradient are specified for the measurement chain. To complete the calibration, use buffer solutions in accordance with DIN 19266.

Note: a pH calibration can only be carried out with an inserted temperature sensor.

Reset pH probe:

Reset the pH measuring reference.

Display:

Display the measured pH value on working screen.



Operating Mode:

Mode A:

After power on/power failure no automatic restart of functions.

Mode B:

After power on/power failure automatic restart of functions, depending on previous settings.

Mode C:

Set values (set in **A** or **B**) cannot be changed.

After power on/power failure automatic restart of functions, depending on previous settings.



Display:

Here the user can specify which information (torque trend, pH value, or timer value) is to be displayed on the working screen.



Safety:

Time Out:

Here you can set a time out. This time out goes into effect if the communication between the device and the PC has failed. In this case, the device continues to run with the set speed and temperature.

Password:

In the menu, the user can protect the device settings using a password. The user is requested to input the password in order to access the working screen (factory setting: 000).

Safe temperature confirmation:

Here you must confirm the safety temperature value of the heating block.



Settings:

Languages:

Here allows the user to select the desired language by turning and pressing the rotary/push knob (**A**). A tick indicates the language that is set for the system.

Display:

Here allows the user to change the background color of the working screen.

Sound:

Here allows the user to activate/deactivate the key-press sound and to set the volume.

Factory settings:

Here the user can reset the device to factory settings. The system requests confirmation to recreate the factory settings. Pressing the "**OK**" button resets all the system settings to the original standard values set at dispatch from the factory.

Information:

The "**Information**" option offers the user an overview of the most important system settings of the device.

Interfaces and output

The device can be operated in "Remote" mode via the RS 232 interface or the USB interface connected to a PC and with the laboratory software Labworldsoft®.

Note: Please comply with the system requirements together with the operating instructions and help section included with the software.

USB interface

The Universal Serial Bus (USB) is a serial bus for connecting the device to the PC. Equipped with USB devices can be connected to a PC during operation (hot plugging). Connected devices and their properties are automatically recognized. Use the USB interface in conjunction with Labworldsoft® for operation in "Remote" mode and also to update the firmware.

USB device drivers

First, download the latest driver for **IKA**® devices with USB interface from <http://www.ika.com/ika/lws/download/usb-driver.zip> and install the driver by running the setup file. Then connect the **IKA**® device through the USB data cable to the PC.

The data communication is via a virtual COM port. Configuration, command syntax and commands of the virtual COM ports are as described in RS 232 interface.

RS 232 interface

Configuration

- The functions of the interface connections between the machine and the automation system are chosen from the signals specified in EIA standard RS 232 in accordance with DIN 66 020 Part 1.
- For the electrical characteristics of the interface and the allocation of signal status, standard RS 232 applies in accordance with DIN 66 259 Part 1.
- Transmission procedure: asynchronous character transmission in start-stop mode.
- Type of transmission: full duplex.
- Character format: character representation in accordance

with data format in DIN 66 022 for start-stop mode. 1 start bit; 7 character bits; 1 parity bit (even); 1 stop bit.

- Transmission speed: 9600 bit/s.
- Data flow control: none
- Access procedure: data transfer from the stirrer machine to the computer takes place only at the computer's request.

Command syntax and format

The following applies to the command set:

- Commands are generally sent from the computer (Master) to the stirrer machine (Slave).
- The stirrer machine sends only at the computer's request. Even fault indications cannot be sent spontaneously from the stirrer machine to the computer (automation system).
- Commands are transmitted in capital letters.
- Commands and parameters including successive parameters are separated by at least one space (Code: hex 0x20).
- Each individual command (incl. parameters and data) and each response are terminated with Blank CR LF (Code: hex 0x20 hex 0x0d hex 0x20 hex 0x0A) and have a maximum length of 80 characters.
- The decimal separator in a number is a dot (Code: hex 0x2E).

The above details correspond as far as possible to the recommendations of the NAMUR working party (NAMUR recommendations for the design of electrical plug connections for analogue and digital signal transmission on individual items of laboratory control equipment, rev. 1.1).

The NAMUR commands and the additional specific **IKA**® commands serve only as low level commands for communication between the machine and the PC. With a suitable terminal or communications programme these commands can be transmitted directly to the equipment. The **IKA**® software package, labworldsoft®, provides a convenient tool for controlling device and collecting data under MS Windows, and includes graphical entry features, for motor speed ramps for example.

The following table summarises the (NAMUR) commands understood by the **IKA**® control equipment.

Abbreviations used:

- X,y = numbering parameter (integer number)
- m = variable value, integer
- n = value of variable, floating point number
- X = 1 Pt100 thermometer (external temperature sensor)
- X = 2 temperature (heating block)
- X = 3 safety temperature
- X = 4 stirring speed
- X = 6 safety stirring speed

Commands:

NAMUR Commands	Function
IN_NAME	Input description name
IN_PV_X X=1;2;3;4;	Reading the real value
IN_SOFTWARE	Input software ID number date, version
IN_SP_X X=1;2;3;4;6;	Reading the set rated value
IN_TYPE	Input laboratory unit ID
OUT_NAME	Output description name. (Max. 10 characters, default: LR 1000)
OUT_SP_12@n	Setting the WD safety temperature with the echo of the set value
OUT_SP_42@n	Setting the WD safety speed with the echo of the set value
OUT_SP_X n X=1;2;4;6	Setting the rated value to n
OUT_WD1@m	Watchdog mode 1: When a WD1 event occurs, the heating and Stirring functions are shut down and message PC 1 is displayed. Set the watchdog time to m (20...1500) seconds, with echo of the watchdog time. This instruction starts the watchdog function and must be sent within the set watchdog time.
OUT_WD2@m	Watchdog mode 2: When a WD2 event occurs, the speed setpoint will be set to the WD safety setpoint speed and the temperature setpoint will be set to the WD safety setpoint temperature. The PC 2 warning is displayed. The WD2 event can be reset with OUT_WD2@0-resetting also blocks the watchdog function. Set the watchdog time to m (20...1500) seconds, with echo of the watchdog time. This command starts the watchdog function and must be sent within the set watchdog time.
RESET	Switching off the instrument function.
START_X X=1;2;4	Starting the instrument's (remote) function
STATUS	Display of status 1S: mode of operation A 2S: mode of operation B 3S: mode of operation C 50: manual operation without fault S1: Automatic operation Start (without fault) S2: Automatic operation Start (without fault) <0: error code: (-1) - 1: error 1 - ... (see table) -31: error 31 -83:wrong parity -84: unknown instruction -85:wrong instruction sequence -86: invalid rated value -87: not sufficient storage space
STOP_X X=1;2;4	Switching off the instrument - (remote) function Variables set with OUT_SP_X are maintained.

“Watchdog” function, monitoring the serial data flow

The following applies to situations where the watchdog function is enabled (see Namur instructions). If no new transmissions of these commands from the PC take place within the preset watchdog time, the heating and shaking functions will be shutdown according to the watchdog mode selected or will be controlled using the preset setpoints. An operating system crash, a PC power failure or a fault in the connecting cable to the instrument can cause an interruption in data transmission.

“Watchdog”– Mode 1

If an interruption in data transmission occurs which is longer than the preset watchdog time, the heating and shaking functions will be shut down and the error message PC 1 will be displayed.

“Watchdog”– Mode 2

If an interruption in data transmission occurs which is longer than the preset watchdog time, the speed setpoint value will be set to the WD safety speed setpoint and the temperature setpoint will be set to the WD safety temperature setpoint. The PC 2 warning message will be displayed.

PC 1.1 Cable:

Required for connecting the RS 232 port to a PC.

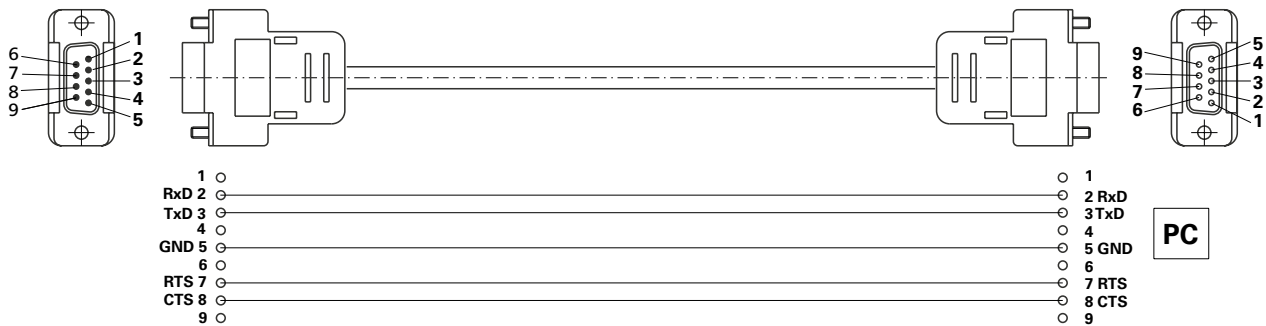

Fig. 19

USB cable A - Micro B 2.0:

This cable is required to connect USB port (9, see Fig. 2) to a PC.

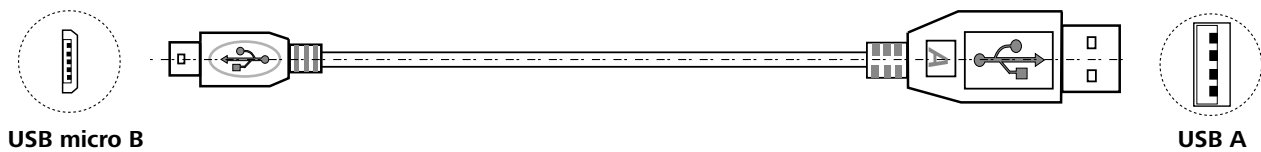
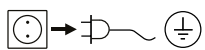

Fig. 20

Maintenance and cleaning

Cleaning:

 For cleaning disconnect the main plug!

Disassemble the reactor vessel:

Remove the reactor vessel from the **LR basic/control** base.
Remove the reactor cover from the reactor vessel.
Remove the glass tube from the base as described below.
Use a screwdriver to loosen and remove the four screws on the two clamps.



Fig. 21

Now both clamps can be removed. Then remove the glass tube with handles from the base.

Remove both handles from the glass vessel as following.
Reserve the glass tube with handles. Loosen both screws with screw driver at the bottom of handles (see Fig. 22).



Fig. 22

Then, both handles can be removed from the glass vessel.

Note: the screws can only be loosened and cannot be removed from the handles.

Disassemble the anchor stirrer:

After removing the glass tube from the vessel base, the anchor stirrer together with the reactor vessel bottom of the socket can be taken apart from the vessel base (see Fig. 23).



Fig. 23

Please pay attention to the O-ring when you disassemble the reactor vessel.

Open the screw as described in Fig. 24 with the socket wrench.

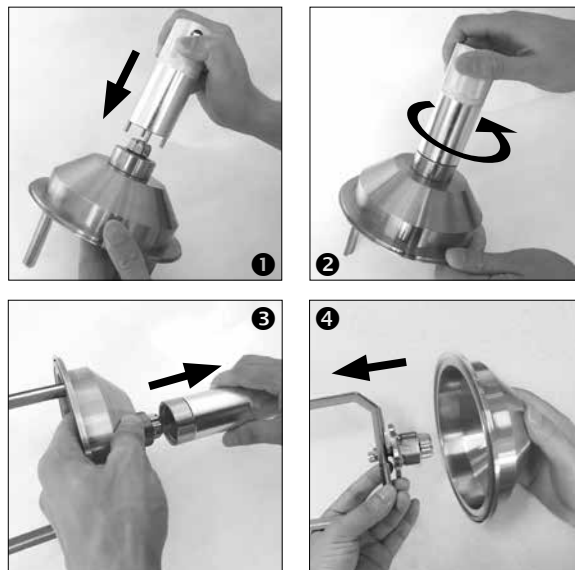
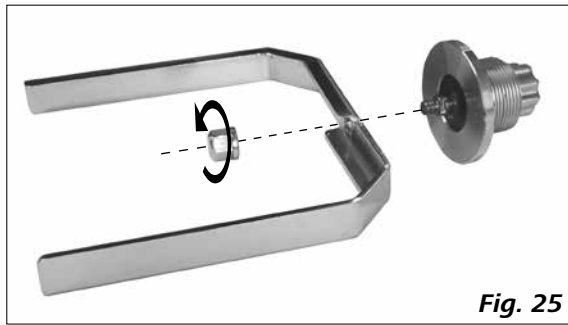

Fig. 24

Now you can remove the anchor stirrer as shown in **Fig. 25**. All O-rings can now be carefully removed by hand or using a blunt tool for cleaning too.



- Wear protective gloves during cleaning the instrument.
- Electrical devices may not be placed in the cleaning agent for the purpose of cleaning.
- Do not allow moisture to get into the equipment when cleaning.
- Please consult **IKA®** before using any cleaning or decontamination methods, other than those recommended here.
- The handles cannot be placed in the cleaning agent for cleaning.
- The only cleaners or disinfectants that may be used are those that:
 - lie in the pH range 5 - 8,
 - contain no corrosive alkalis, peroxides, chlorine compounds, acids or brine.
- All product contacting components are suited for cleaning in the laboratory dish washers.

Only clean **IKA®** appliances using these **IKA®** approved cleaning agents.

Dirt	Cleaning agent
Dyes	Isopropanol
Building materials	Water containing detergent, Isopropanol
Cosmetics	Water containing detergent, Isopropanol
Food	Water containing detergent
Fuels	Water containing detergent
Other materials	Please consult IKA®

Spare parts order:

When ordering spare parts, please give:

- machine type
- serial number, see type plate
- item number and designation of the spare part see **www.ika.com**, spare parts diagram and spare parts list.

Repair:

Please send equipment for repair only after it has been cleaned and is free from any materials which may constitute a health hazard.

For repairing, please request the “**Decontamination Certificate**” from **IKA®**, or download the printout of it from the **IKA®** website **www.ika.com**.

If you require servicing, return the equipment in its original packaging. Storage packaging is not sufficient. Please also use suitable transport packaging.

Error codes

The fault is shown by an error message in the display as following if the error occurs.

Proceed as follows in such cases:

- Switch off the device using the main switch
- Carry out corrective measures
- Restart the instrument

Error code	Description	Effect	Corrective action
Error 3 (Er 3)	Internal temperature of device is too high.	Heating off Motor off	- Switch off the instrument and allow it to cool down.
Error 4 (Er 4)	Motor is blocked or overloaded.	Motor off	- Switch off the instrument - Decrease the load and restart again
Error 10 (Er 10)	Remote control is interrupted.	Heating off Motor off	- Change watchdog time - Check relating connection
Error 11 (Er 11)	External temperature sensor plugged during heating control.	Heating off	- Unplug the external temperature sensor.
Error 12 (Er 12)	External temperature sensor unplugged during heating control.	Heating off	- Plug in the external temperature sensor
Error 14 (Er 14)	Short circuit of external temperature sensor or cable.	Heating off	- Check the external temperature sensor and cable
Error 18 (Er 18)	The temperature of safety sensor is higher than safety temperature setting.	Heating off	- Increase the safety temperature setting or allow cooling down
Error 51 (Er 51)	Mains voltage is too high.	Heating off Motor off	- Switch off the device and check the mains voltage.
Error 52 (Er 52)	Mains voltage is too low.	Heating off Motor off	- Switch off the device and check the mains voltage.
Er 60 ❶	Power is interrupted when heating or motor control is activated in Mode B and C	–	- Exit error state when any button is pressed.

❶ Only for **LR 1000 basic!**

If the actions described fails to resolve the fault or another error code is displayed then take one of the following steps:



- Contact the service department
- Send the instrument for repair, including a short description of the fault.

Warranty

In accordance with **IKA®** warranty conditions, the warranty period is 24 months. For claims under the warranty please contact your local dealer. You may also send the machine direct to our factory, enclosing the delivery invoice and giving reasons for the claim. You will be liable for freight costs.

The warranty does not cover worn out parts, nor does it apply to faults resulting from improper use, insufficient care or maintenance not carried out in accordance with the instructions in this operating manual.

Accessories

T 25 digital	Disperser	LR 1000.20	Flow breaker/baffle
S 25 KV - 25 F	Dispersing element	RC 2 basic	Thermostat
S 25 KV - 25 G	Dispersing element	RC 2 control	Thermostat
S 25 KV - 18 G	Dispersing element	HPVC 8	PVC hose
LR 1000.41	Shaft receptacle	MVP10 basic	Vacuum pump
LR 1000.61	Sensor receptacle	VCV1	Vacuum control valve
LR 1000.65 	pH electrode receptacle	VSS1	Vacuum safety set
LR 1000.64 	pH Electrode	labworldsoft®	

 Only for **LR 1000 control!**

See more accessories on www.ika.com.

Materials in contact with medium

Reactor cover	AISI 316 L / AISI 316 TI / PTFE / Borosilicate glass 3.3
Bottom	AISI 316 L / AISI 316 TI
Reactor vessel	Borosilicate glass 3.3
Anchor stirrer	AISI 316 L / AISI 316 TI
Temperature sensor	AISI 316 L / AISI 316 TI
Shaft seal	PTFE
LR 1000.1	
O-ring	FKM
LR 1000.3	
O-ring	FFKM
Scraper	PEEK

Technical data

		LR 1000 basic	LR 1000 control
Nominal voltage	VAC	100 – 120 230	
Frequency	Hz	50 / 60	
Input power	W	1200	
Viscosity max.	mPas	100000	
Usable volume	ml	300 – 1000	
Useful volume with dispersing	ml	500 – 1000	
Attainable vacuum	mbar	25	
Stirring speed range	rpm	10 – 150	
Speed display		LED	TFT
Speed setting resolution	rpm	1	
Speed deviation	rpm	± 5	
Working temperature max. (medium)	°C	120	
Temperature display		LED	TFT
Temperature setting resolution	K	1	0.1
Temperature measurement resolution	K	0.1	
Heating control accuracy	K	± 1	
Connection for external temperature sensor		Pt 100	
Control accuracy with external sensor	K	± 0.2	
Adjustable safety circuit	°C	47 (± 10) – 225 (± 20)	
Type of cooling		Liquid through cooling	
Minimum temperature of the cooling medium	°C	3	
Cooling medium permissible pressure	bar	1	
Weighing range	kg	-	0 – 2
Weighing resolution	g	-	1
pH meter interface		no	yes
pH value display		-	TFT
pH display range		-	0 – 14
pH display resolution		-	0.1
Nominal torque	Ncm	3	
Torque trend display		-	TFT
Timer function		yes	
Timer display		LED	TFT
Interface		USB, RS 232	
Protection class acc. to EN 60529		IP 21	
Permissible ambient temperature	°C	+5 ... +40	
Permissible ambient humidity (relative)	%	80	
Dimension (W x D x H)	mm	443 x 295 x 360	
Weight	kg	16	
Operation at a terrestrial altitude	m	max. 2000	

Subject to technical changes!

IKA® - Werke GmbH & Co.KG

Janke & Kunkel-Str. 10

D-79219 Staufen

Tel. +49 7633 831-0

Fax +49 7633 831-98

sales@ika.de

www.ika.com